



Service Manual

Crown Pallet Jack

Models: PTH and PTH50

Developed by

Super Stores Service

This manual is intended for basic service and maintenance of the Crown pallet jack.

The pallet jacks you are servicing are tools that make moving products easier. Operating pallet jacks with rusty, broken or worn parts makes usage and maintenance more difficult.

Pallet jack parts are inexpensive and easy to replace. To ensure maximum life of the jack, always replace the parts that are broken or worn. Remember that all parts on a pallet jack depend on the adjoining parts to work properly and to perform to their full potential. When used in conjunction with our catalog, this service manual will explain how and when to replace a pallet jack part.

Remember, when in doubt...replace it.

If you have any questions, just call us. We make it easy!

1-800-462-2370

Fax 1-800-366-5939 • www.SuperStoresService.com

US \$ 19.95
CAN \$ 29.95

Contents

2	Suggested Assemblies	
3	Commonly Used Tools	
3	Helpful Reminders	
4	Axles	
4	Bushings	
5	Load Rollers and Load Roller Brackets	(30 min.)
6	Steer Wheels and Axle	(30 min.)
7	Traverse	(40 min.)
8	Push Rods	(40 min.)
9	Lifting Link	(75 min.)
10	Handle Removal and Installation	(40 min.)
	Hydraulic Unit:	
12	Inspection	
13	Service Hints	
14	Removal	(45 min.)
14	Installation	(45 min.)
15	Diagram	

Copyright © 1999 by GPS, Inc. All rights reserved.

Crown PTH and PTH50 pallet jacks are products of Crown Equipment Corp.

Labor time estimates include disassembly, repair and clean-up. Please note that these times are calculated at a rate comparable to a novice technician. Times will vary due to age and condition of the equipment.

Suggested Assemblies to Save Repair Time

PTH50

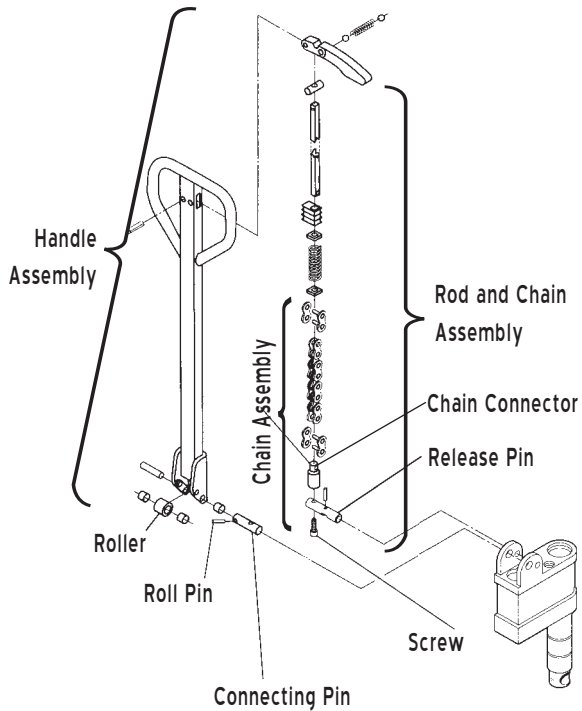

- CR 44506-001-D-SUPER
Super Ultra-Poly Load Roller Assembly
- CR 44495-001
Ultra-Poly Steer Wheel Assembly
- CR 44648-SUPER
Super Seal Kit
- CR 44521-012
Handle Assembly
- CR 44527-A
Rod and Chain Assembly
- CR 44533-A
Chain Assembly
- CR RPK50
Roll Pin Kit

PTH

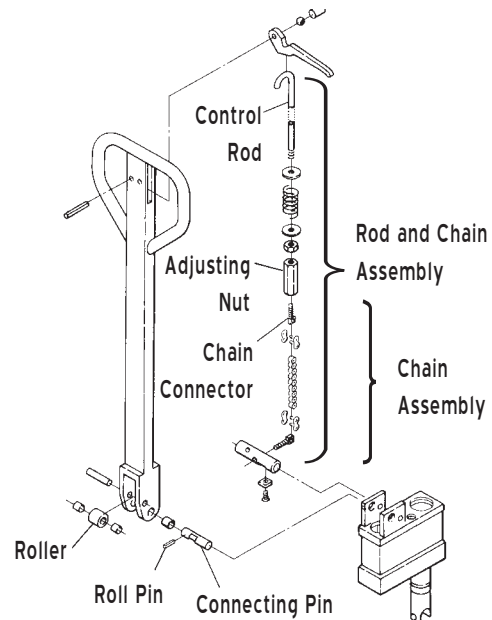

- CR 82283-1-D-SUPER
Super Ultra-Poly Load Roller Assembly
- CR 41275-1-D
Ultra-Poly Steer Wheel Assembly
- CR 43023-SUPER
Super Seal Kit
- CR 41293
Handle Assembly
- CR 41295-A
Rod and Chain Assembly
- CR 79904-A
Chain Assembly
- CR RPK
Roll Pin Kit

Commonly Used Tools

- Hammer
- Jack stand
- 45° Snap ring pliers (large and small)
- 13 mm Wrench (for entry rollers)
- 3 mm Allen wrench
- 3/16" Pin punch
- 3/8" Pin punch
- Crown Bushing extractor (this custom tool is available only through us)
- Soft hammer (nylon mallet)
- Anti-seize compound
- Lubricant (i.e. WD40 may be necessary to remove rusted parts)

PIN PUNCH

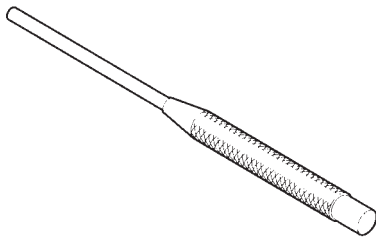

BUSHING EXTRACTOR

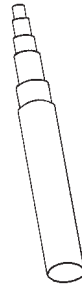

SNAP RING PLIERS

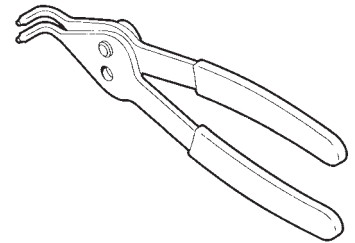

Helpful Reminders

- Never hammer directly on an axle; always use a pin punch.
- Always replace old roll pins. The PTH 50 has blind roll pin holes in the pivot axle and in the shoulder pins. It is very important to use the correct roll pin in these locations to prevent damage to the mating parts.
- Replace accessible bushings whenever the jack is disassembled. Our custom designed bushing extractor makes it quick and easy to remove all bushings on the Crown jack.
- Serial numbers can be found on the A-Frame.
Crown PTH Serial numbers are 3-118400 to 3-999999.
Crown PTH50 Serial numbers are 7-000000 and higher.

Axles

Inspection

If the axle is bent, out-of-round, or shows signs of wear, replace it. Check for worn roll pin holes. If these are damaged or worn, replace the axle.

Bushings

Bushings are designed to wear out sooner than the mating parts. They are made of softer material and are expendable. It is recommended that any time the jack is torn down to a point where the bushings are accessible, they be replaced. This will ensure longer life of the jack and will reduce the amount of downtime. Bushings are very inexpensive and it is cost-effective to change them regularly.

Inspection

If bushings are cracked, broken, egg-shaped or worn more than $\frac{1}{16}$ " from the original size, replace them.

Remember: If the jack is already disassembled, replace all accessible bushings.

Tip: Coating axles and bushings with anti-seize compound before installation makes maintenance easier.

Load Roller and Load Roller Brackets

Inspection

Load rollers - Load rollers should have neither flat spots nor large pieces of metal imbedded in them (i.e. tacks, nails or metal shavings). Any chips in the wheel that keep it from rolling smoothly indicate the need for replacement. If the wheel has cracks, loose tread, or does not turn freely, replace both wheels. Always change the wheels in pairs to reduce uneven wear. New load rollers have an outside diameter of 3" (PTH50) or 3 1/4" (PTH). If the diameter is worn more than 1/4" from normal size, replacement is necessary.

Load roller brackets - Inspect the brackets for cracks or wear from prolonged rubbing on the floor. Check for out-of-round axle holes and inspect the bushings closely (see *Bushing Inspection*). If any of the above conditions exist, replace the brackets.

Removal

Tip: We recommend servicing one load roller assembly at a time, while using the other assembly as reference.

PTH

Load roller - Pump the jack to expose the load roller brackets and then turn the jack on its side. Use a hammer and pin punch to remove both of the roll pins in the load roller brackets that secure the load roller axle in place. Drive the axle out with the punch and remove the load roller.

(10 minutes)

Load roller brackets - Remove the load roller. Drive the roll pins out of the pivot axle that hold the exit roller in place, as well as the roll pin that fastens the pivot axle to the frame. Drive the pivot axle out, pull the push rod away from the frame, and pull the brackets off of the push rod.

(15 minutes)

Installation

PTH

Load roller brackets - Slide the brackets on to the push rod. Insert the pivot axle through the frame, brackets and the exit roller. Secure the pivot axle to the frame with the roll pin. Position the exit roller between the two roll pin holes, then hammer the two roll pins in to keep the exit roller in place. (15 minutes)

Load rollers - Insert the load roller axle through the brackets and load roller, then secure the axle to the brackets with the two roll pins.

(10 minutes)

PTH

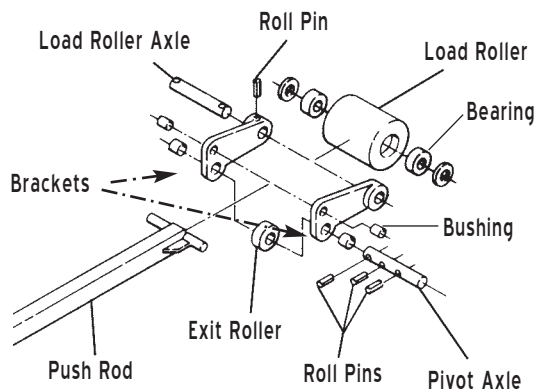

PTH50

Load roller - Pump the jack to expose the load roller brackets and then turn the jack on its side. Use a hammer and pin punch to remove both of the roll pins in the load roller brackets that secure the load roller axle in place. Drive the axle out with the punch and remove the load roller. (10 minutes)

Load roller brackets - Remove the load roller. Drive the roll pin that fastens the pivot axle to the frame into the axle (this is a blind roll pin hole). Remove the pivot axle just enough to be able to drive the roll pin out of the axle, then drive the pivot axle completely out. Pull the push rod away from the frame and pull the brackets off of the push rod.

(15 minutes)

PTH50

Load roller brackets - Slide the brackets on to the push rod. Insert the pivot axle through the frame, exit roller and brackets. Line up the roll pin hole and secure the pivot axle to the frame with the roll pin.

(15 minutes)

Load rollers - Insert the load roller axle through the brackets and load roller, then secure the axle to the brackets with the two roll pins.

(10 minutes)

PTH50

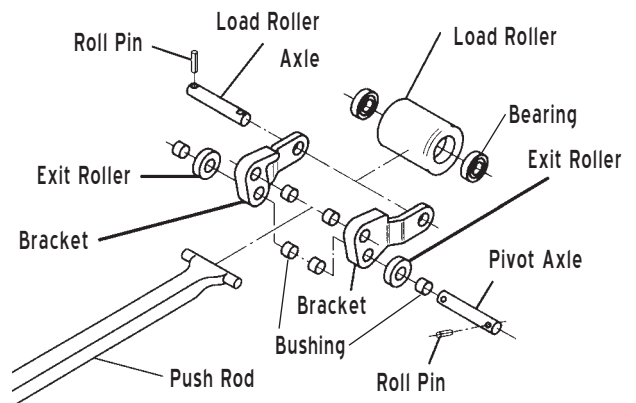

Steer Wheels and Axle

Inspection

Steer wheels should have neither flat spots nor large pieces of metal imbedded in them (i.e. tacks, nails, or metal shavings). Chips in the wheel which keep it from rolling smoothly indicate replacement. Steer wheels should turn freely. They should not rub the bottom of the traverse. If they do, check for the correct installation of the snap ring under the traverse. The PTH50 uses 7" wheels, and the PTH uses 8" wheels. If the diameter is worn more than 1/4" from the normal size, replacement is necessary.

Removal

PTH

Steer wheels - Turn the jack onto its side, remove the snap ring attaching the wheel to the axle, and the wheel may be removed.

(10 minutes)

Steer wheel axle - Turn the jack onto its side. Remove the steer wheels, the roll pins and fastening pin connecting the steer wheel axle to the bottom of the hydraulic unit. The axle will slide out. (15 minutes)

PTH50

Steer wheels - Remove the hubcap and then the snap ring. The wheel is now free and may be removed. (10 minutes)

Steer wheel axle - Turn the jack onto its side. Remove the hub cap and the snap ring, and slide the steer wheel off of the axle. Remove the roll pin holding the axle to the hydraulic unit stem and drive the axle out with a soft hammer. (15 minutes)

Installation

PTH

Steer wheels - Slide the wheel onto the axle and attach the snap ring. (10 minutes)

Steer wheel axle - Slide the axle into the bottom of the hydraulic unit and secure with the fastening pin and its roll pins. Then slide the steer wheels on to the axle and attach snap rings. (15 minutes)

PTH50

Steer wheels - Slide the wheel onto the axle and attach the snap ring. (10 Minutes)

Steer wheel axle - Slide the axle into the bottom of the hydraulic unit and fasten with the roll pin. Then secure the steer wheels. (15 Minutes)

PTH

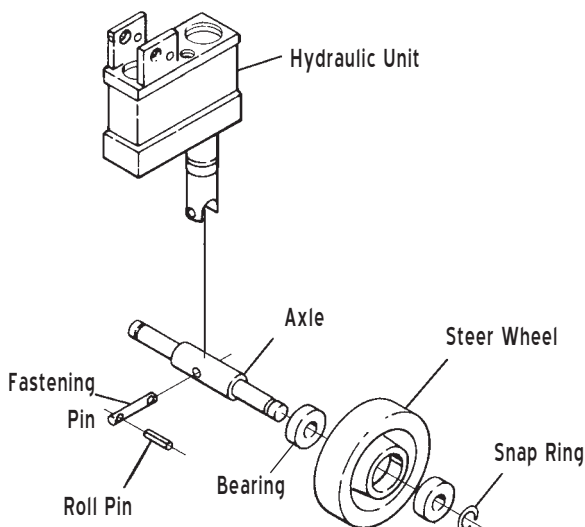

PTH50

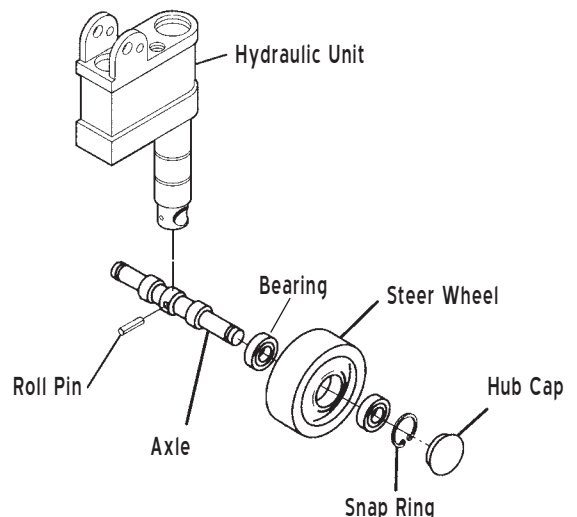

Traverse

Inspection

There are few things that can be wrong with the traverse. Wear can occur on the bearing shoulder or where the shoulder bolts attach to the lifting link. If these areas are egg-shaped or out-of-round, replace the traverse.

Removal

Pump the jack to maximum height and turn the jack onto its side. Remove the steer wheels and axle (*see Steer Wheels and Axle Removal*) and the snap ring under the traverse on the stem of the hydraulic unit. Turn the jack upright; be careful not to damage the stem of the hydraulic unit while lowering. Remove the roll pin that fastens the top of the ram to the frame. Lift the frame off of the ram, tip the handle and hydraulic unit away from the frame, and rest both pieces on the ground. Remove the ball on top of the ram (PTH50 only) and pull the hydraulic unit out of the traverse. On the PTH, remove the roll pins holding the shoulder pins in the traverse. Remove the shoulder pins and the traverse. On the PTH50, use a pin punch and hammer to drive the shoulder pins roll pins into the shoulder pins until they are flush. Remove the shoulder pins and the traverse. (20 minutes)

Installation

Attach the traverse to the lifting link with the shoulder pins and secure the shoulder pins with the roll pins. Slide the stem of the hydraulic unit into the traverse with the traverse bearing already in place on the stem. Insert the ram into the A-Frame with the ball positioned on the top of the ram and secure the ram to the A-Frame with the screw. Carefully turn the jack onto its side, keeping the hydraulic unit in the traverse and frame. Attach the snap ring to the stem of the hydraulic unit under the traverse. Install the steer wheel assembly (*see Steer Wheels and Axle Installation*) and the handle, if necessary (*see Handle Installation*). Bleed the hydraulic unit (*see Air Lock and Pump*). (20 minutes)

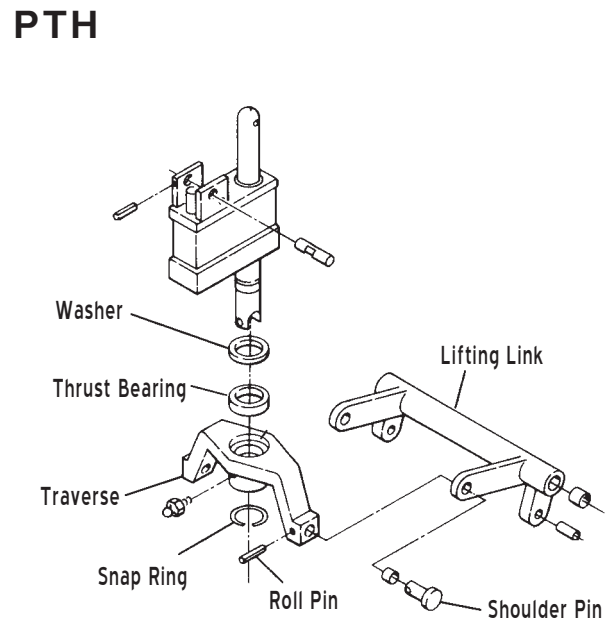
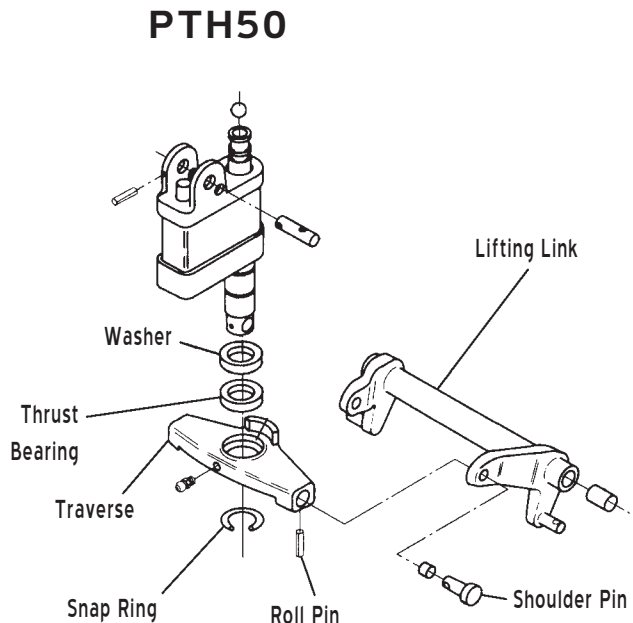

Push Rods

Inspection

When inspecting the push rods, look for broken or cracked welds, bends, and out-of-round holes. If any of the above conditions exist, replace the push rod. We suggest that you work on one side of the jack at one time, so you can use the other side as a reference.

Removal

Turn the jack over so the undercarriage is facing up. Remove the load roller brackets (see *Load Roller Brackets*). On the PTH, remove the roll pin and pin that fastens the push rod to the lifting link. On the PTH50, remove the roll pin that fastens the push rod to the lifting link. (20 minutes)

Installation

Turn the jack over so the undercarriage is facing up. Set the push rods in the frame. The end of the push rod connecting to the load roller brackets is angled. The push rod should be positioned so that the angled side faces the ground when the jack is turned upright. Slide the push rod onto the lifting link and fasten by inserting the roll pin. On the PTH, install the pin that connects the push rod to the lifting link and insert the roll pin. Install the load roller brackets (see *Load Roller Brackets Installation*). (20 minutes)

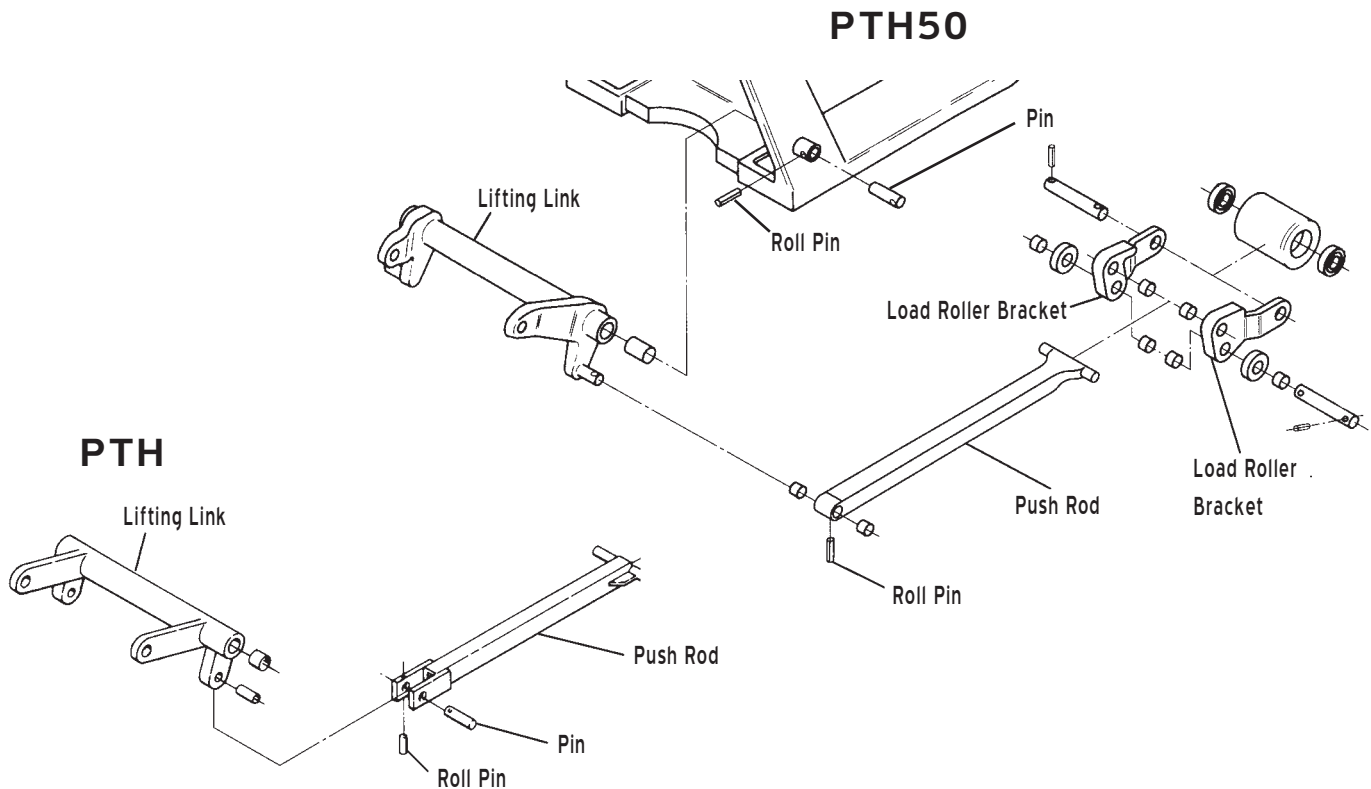

Lifting Link

Inspection

Check the lifting link for out-of-round holes, cracks in welds, or bent ears. If any of these conditions exist, replace the lifting link. Also check the integrity of the bushings, shoulder pins, lifting link pins or the roll pins that fasten these parts to their mating parts.

Removal

First, remove the hydraulic unit (*see Hydraulic Unit*). Remove the traverse (*see Traverse*). Remove load roller brackets (*see Load Roller Brackets*) and both of the push rods (*see Push Rods*). Remove the roll pins that fasten the lifting link pins to the frame. Extract the lifting link pins from the frame and then the lifting link. (35 minutes) *See Figures 1 and 2 on page 11.*

Installation

Place the lifting link in position and insert the lifting link pins. Insert the roll pins that fasten the lifting link pins to the frame. Install the push rods (*see Push Rods*). Install the load roller brackets (*see Load Roller Brackets*). Install the traverse (*see Traverse*). Install the hydraulic unit (*see Hydraulic Unit*). (40 minutes)

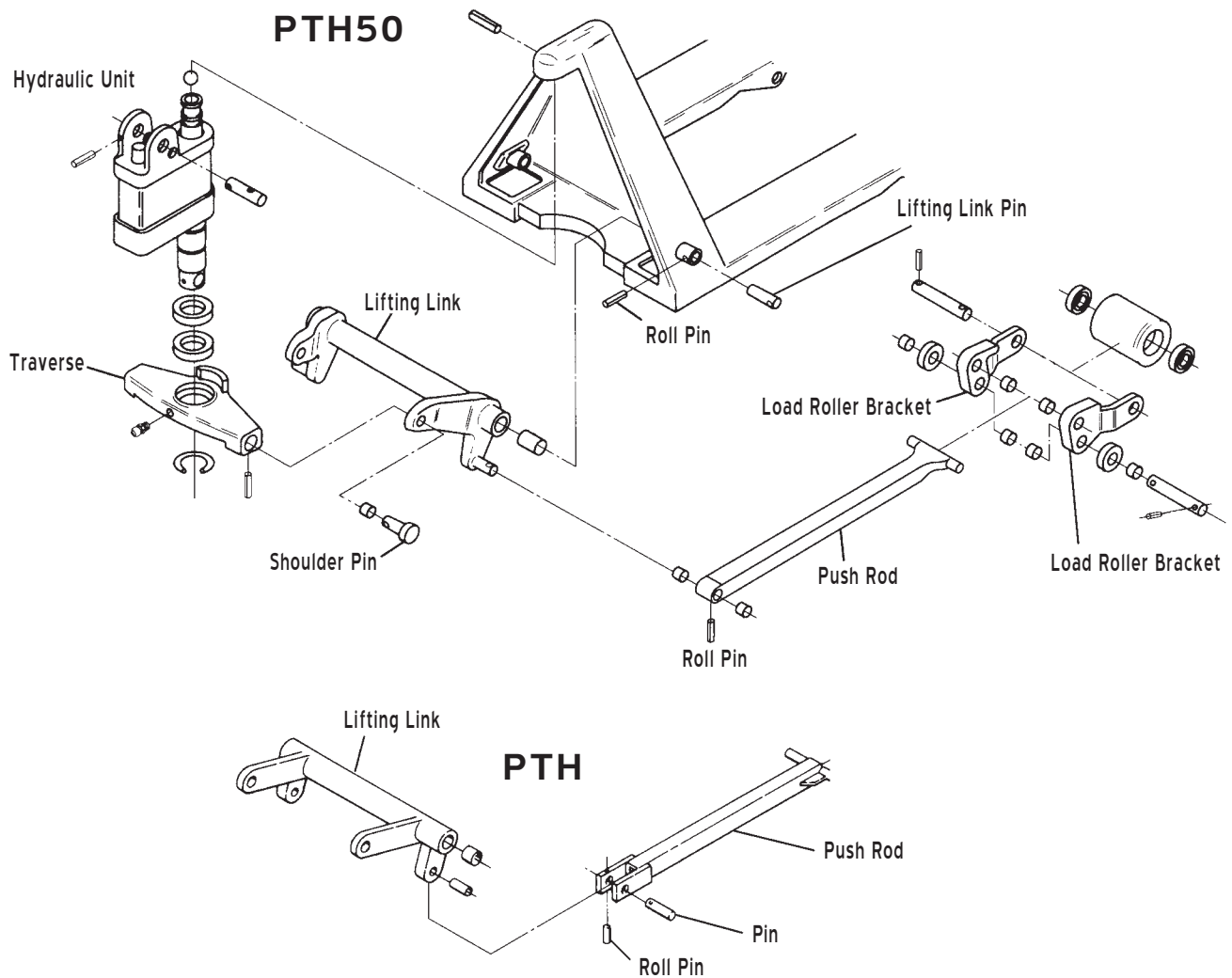

Handle Removal and Installation

Inspection

Inspect the handle for cracks and structural integrity. There should be minimal side play in the handle bracket. Check for worn bushings. If bushings are not replaced regularly, the handle bracket holes can become worn. Damaged holes cause pin failure and may require complete replacement. Also, inspect the handle pin and roller for flat areas and wear. If any of the above parts are worn more than 1/16", replace them.

Newer and Older PTH

Place the hand control in the lift position. Loosen the nut above the adjusting nut and turn the adjusting nut until most of the slack on the chain is taken up. Test the adjustment by pumping the handle to see if the jack rises. If it does not raise, readjust until the jack rises. Put the control lever into neutral and pump the handle. The jack should remain at the same height. If it continues to rise, the chain is too loose. If the jack lowers, the chain is too tight and needs to be readjusted. Put the control lever into the release position. The jack should lower now. If not, inspect the actuating pin, the actuating plate, and the release pin to ensure they are not worn. If the release pin is sticking, your hydraulic unit needs servicing.

Crown PTH50

Place the control lever in the lift position and adjust the barrel nut so that there is little slack in the chain. Test by pumping the handle. The jack should raise now. Put the control lever in the neutral position and pump the handle. The jack should remain at the same height. If the jack raises, the barrel nut needs to be adjusted to take up the slack in the chain. If it lowers, the barrel nut needs to be adjusted to allow a little more slack in the chain. Next, place the control lever in release position. The jack should now lower. If not, inspect the actuating pin for wear, the roll pin in the actuating pin (the roll pin should be tapped all the way in to the actuating pin), and the release pin. If the release pin is sticking, your hydraulic unit needs servicing.

Tip: It is easier to install/remove the handle with the hydraulic unit removed. However, it can be done with the hydraulic unit still attached. It is also recommended that you have a partner help you hold the handle in position during installation. Hold the hand release in the up position during the chain removal and in the down position during installation. See Figures 3 and 4 on page 11.

Newer/Older Style Crown PTH

Removal - Disconnect the adjusting nut from the control rod and the chain connector. Pull the chain clear of the connecting pin. Remove the roll pin that fastens the connecting pin to the hydraulic unit. Drive the connecting pin out and remove the handle. (15 minutes)

Installation - Place handle on the hydraulic unit and insert the connecting pin. Insert the roll pin that fastens the pin to the hydraulic unit. Pull the chain connector through the pin, attach the adjusting nut, and screw on to the control rod. Have a partner hold the handle down to allow easier access to the adjusting nut and chain. (25 minutes)

See Diagram on page 15.

Crown PTH50

Removal - Using a 3mm Allen wrench, remove the screw from the chain connector. There is an access slot in the hydraulic unit to reach the screw. Pull the chain clear from all pins. Remove the roll pin that fastens the pin to the hydraulic unit. Punch the connecting pin out, and remove the handle. (15 minutes)

Installation - Place the handle on the hydraulic unit and insert the connecting pin. Insert the roll pin that fastens the pin to the hydraulic unit. Lower the chain connector through the pin using a 3mm Allen wrench. Fasten the chain to the release pin with the screw using the access slot in the hydraulic unit. (25 minutes)



Figure 1

Removal of lifting link

Page 9



Figure 2



Figure 3

Handle adjustments

Page 10

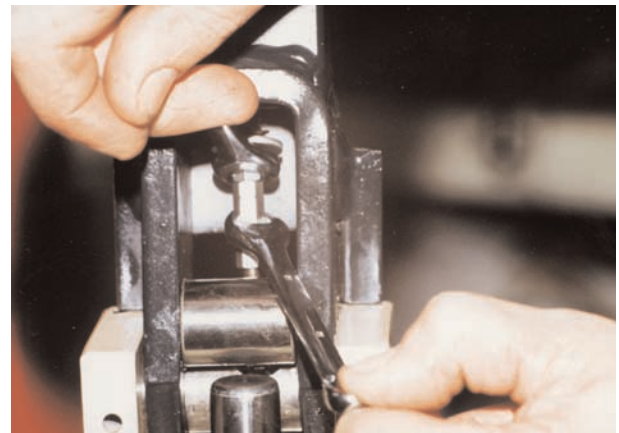

Figure 4

Hydraulic Unit

Inspection

Inspect the outside of the pump for oil leaks. Test the unit, under a load, to determine if there is a problem. This can be done by lifting a heavy pallet and letting it stand for 15-20 minutes. Below are symptoms and solutions to common hydraulic unit failures. If the following solutions fail to correct the problem, send the unit to us. We have the expertise and special tools required to properly rebuild the malfunctioning unit. Please see our catalog for information about our hydraulic unit exchange program.

Jack fails to lift load:

- **Air Lock in Pump** - Place the control mechanism in the release position, then pump handle rapidly 10-15 times. (5 minutes)
- **Low Fluid Level** - With the jack in a lowered position, remove filler plug. Using UNI-HO hydraulic oil, fill the reservoir until the oil is about 1-2" below the top of the reservoir. Bleed the unit (*see Air Lock in Pump*). Replace the filler plug, creating a snug fit. (5 minutes)
Note: Never overfill with oil, as this will blow seals and cause premature leaks and pump failure.
- **Hand Control Out of Adjustment**
 - Newer and Older PTH** - Place control lever in lift position. Loosen the nut above the adjusting nut and turn the adjusting nut until most of the slack on the chain is taken up. Test the adjustment by pumping the handle to see if the jack raises. If it does not raise, readjust until the jack raises. Then, put the control lever into neutral and pump the handle. The jack should remain at the same height. If it continues to raise, the chain is too loose. If the jack lowers, the chain is too tight and needs to be readjusted. Put the control lever into the release position. The jack should lower. If not, inspect the actuating pin, the actuating plate, and the release pin to ensure they are not worn. If the release pin is sticking, your hydraulic unit needs servicing. (15 minutes)
 - Crown PTH50** - Place control lever in lift position and adjust the barrel nut so that there is little slack in the chain. Test by pumping the handle. The jack should raise. Put the control lever in the neutral position and pump the handle. The jack should remain at the same height. If the jack raises, the barrel nut needs to be adjusted to take up the slack in the chain. If it lowers, the barrel nut needs to be adjusted to allow a little more slack in the chain. Next, place the control lever in the release position. The jack should lower. If not, inspect the actuating pin for wear, the roll pin in the actuating pin (the roll pin should be tapped all the way in to the actuating pin), and the release pin. If the release pin is sticking, your hydraulic unit needs servicing. (10 minutes)

Jack fails to lower:

- Look for any bent or damaged frame parts (lifting link, push rod, etc.). Bent or damaged frame parts should be replaced.
- Hand control is out of adjustment (*see Hand Control Out of Adjustment*).
- Debris blocking an oil channel in the hydraulic unit. Contact us for our hydraulic core exchange program.

Jack lifts in short increments:

- Lack of oil pressure - *see Low Fluid Level*

One fork lifts, the other does not:

Check for damage in the following areas and their attached parts:

- Lifting link (lifting link pin and traverse shoulder pin)
- Pushrod
- Load roller bracket (pivot axle)

Service Hints

- Tampering and abuse are two of the most common problems. In most cases, minor repairs become major when inexperienced people attempt to rebuild a hydraulic unit. If you come across a unit that looks like it has been tampered with, send it to us for repair.
- The pump piston and ram are polished to a fine finish for maximum seal life and minimum oil leakage. If you see these surfaces nicked or pitted, this will cause the unit to fail in a short time. Replace the entire hydraulic unit. (A slight amount of oil on these parts is normal and necessary for lubrication.)
- Use UNI-HO hydraulic oil.
Do not use automotive oil or hydraulic brake fluid.

Hydraulic Unit

Removal

Pump the jack to its maximum height and turn the jack onto its side. Remove the steer wheels and axle (*see Steer Wheels and Axle Removal*) and the snap ring under the traverse on the stem of the hydraulic unit. Turn the jack upright; be careful not to damage the stem of the hydraulic unit while lowering. Remove the roll pin that fastens the top of the ram to the frame. Lift the frame off of the ram, tip the handle and hydraulic unit away from the frame, and rest both pieces on the ground. Remove the ball on top of the ram (PTH50 only) and pull the hydraulic unit out of the traverse. Remove the handle and handle bracket if necessary (*see Handle Removal*). (45 minutes)

Installation

Slide the stem of the hydraulic unit into the traverse with the washer and traverse bearing already in place on the stem. Insert the ram into the A-Frame with the ball positioned on the top of the ram (PTH50 only) and secure the ram to the A-Frame with the roll pin. Carefully turn the jack onto its side, keeping the hydraulic unit in the traverse and frame. Attach the snap ring to the stem of the hydraulic unit under the traverse. Install the steer wheel assembly (*see Steer Wheel and Axle Installation*) and the handle, if necessary (*see Handle Installation*). Bleed the hydraulic unit (*see Air Lock and Pump*). (45 minutes)

Hydraulic Unit Diagram

PTH

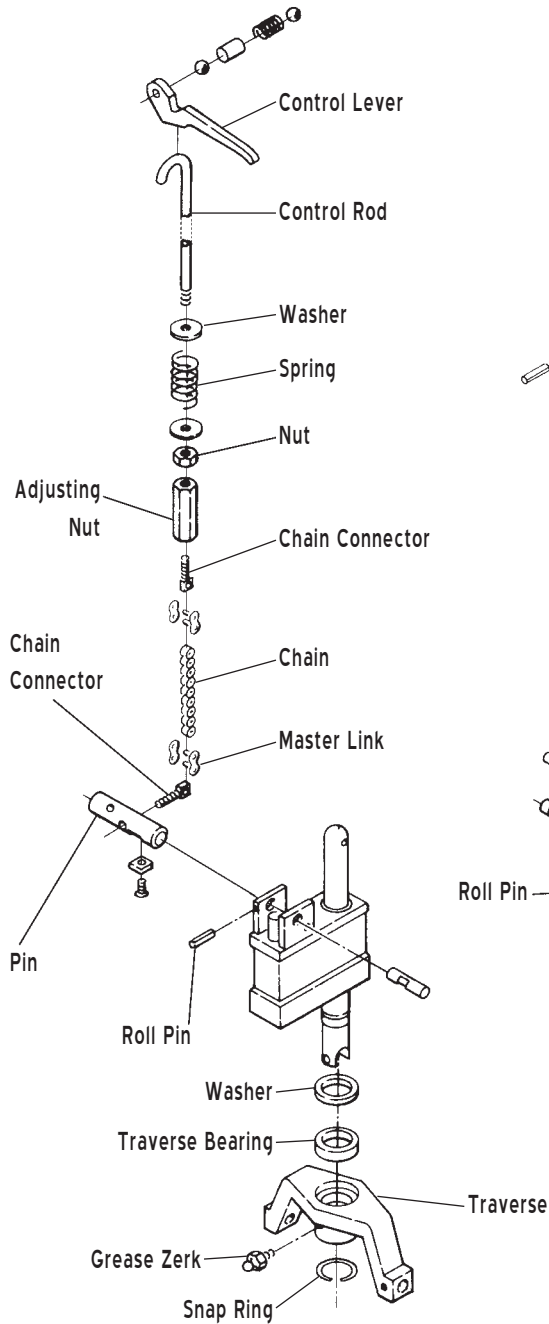

PTH 50

