

**Replacement Parts**  
**for**  
**Hyster W40Z (B218)**  
**Hyster W45Z (C215)**

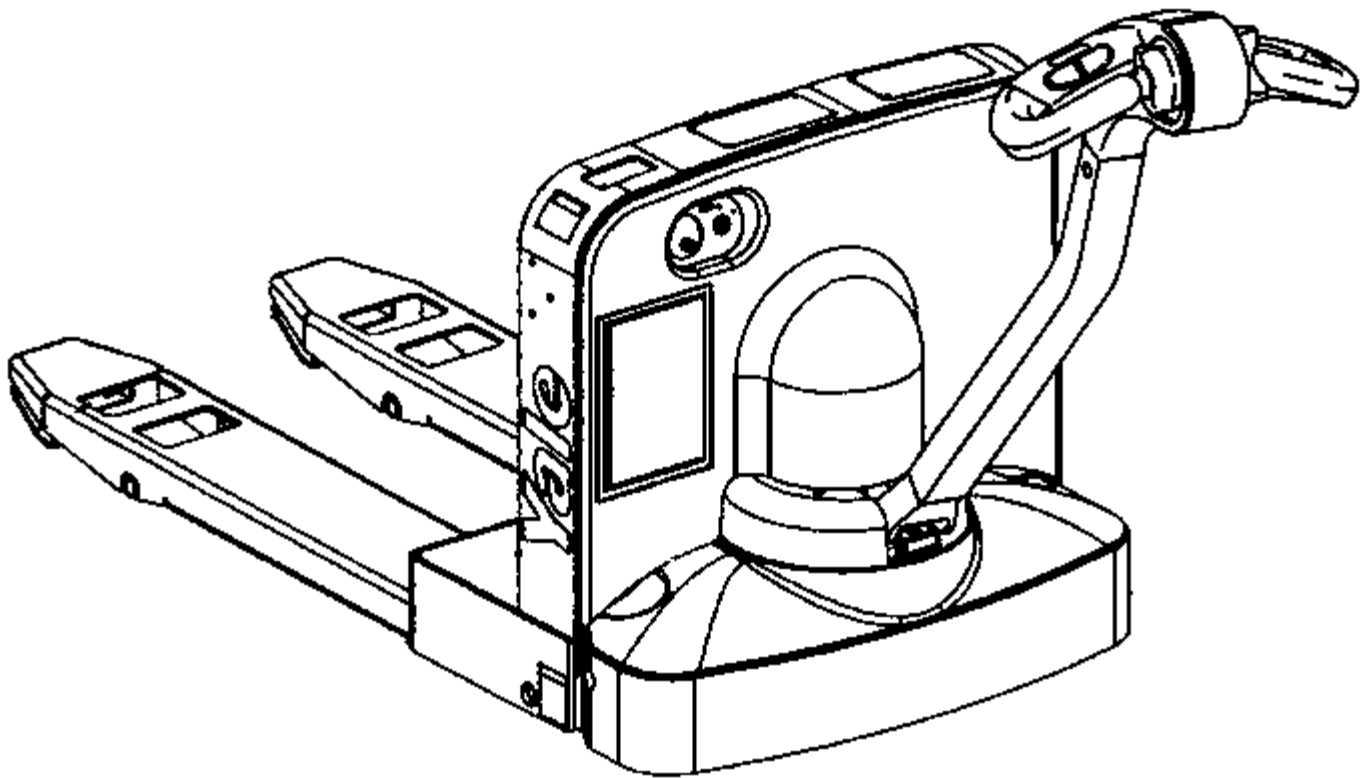

## Truck Data Nomenclature

### Truck Serial # (Stamped on Frame)

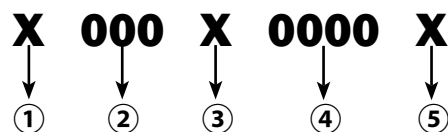

- ①② First letter and next three numbers indicate truck unit code.
- ③ Second letter indicates Plant of manufacturer.
- ④ Four or five digit number indicates production sequence.
- ⑤ Final letter indicates year of manufacturer (see list on right).

Note: Serial number breakdown applies only to trucks built after 1994.

1980	A
1981	B
1982	C
1983	D
1984	E
1985	F
1986	G
1987	H
1988	J
1989	K
1990	L
1991	M
1992	N
1993	P
1994	R
1995	S
1996	T
1997	U
1998	V
1999	W
2000	X
2001	Y
2002	Z
2003	A
2004	B
2005	C
2006	D
2007	E
2008	F
2009	G
2010	H
2011	J
2012	K
2013	L
2014	M
2015	N
2016	P
2017	R
2018	S
2019	T
2020	U
2021	V
2022	W
2023	X
2024	Y
2025	Z

## Contents

<b>Wheels</b>	
<a href="#">Quick Wheel Lookup</a>	4
<hr/>	
<b>Electrical</b>	
<a href="#">Battery Tray and Charger</a>	6
<a href="#">Control Panel</a>	8
<hr/>	
<b>Drive Unit/Brake</b>	
<a href="#">Drive Unit and Brake</a>	10
<hr/>	
<b>Motors</b>	
<a href="#">Drive and Pump Motors</a>	12
<hr/>	
<b>Tiller Arm</b>	
	14
<hr/>	
<b>Control Handle Head</b>	
	16
<hr/>	
<b>Hydraulic</b>	
	18
<hr/>	
<b>Load Wheel and Lift Linkage</b>	
	20
<hr/>	
<b>Caster Assembly - Skid Bar</b>	
	22
<hr/>	

## Quick Wheel Lookup

## Quick Wheel Lookup

[back to Contents](#)

OEM #	Wheel Type	Description	in/mm	Wheel OD in/mm	Tread Width in/mm	Bearing OD #	Bearing Material/Color
HY 2081800	Load Wheel	Load Wheel Assembly, with Shielded Bearings & String Guards, 95-A	3.250/83	4.500/114	2.047/52	BS 6205-ZZ	Scotch, 95-A, Polyurethane
HY 2081796	Load Wheel	Load Wheel Assembly, with Sealed Bearings & String Guards, 95-A	3.250/83	4.500/114	2.047/52	BS 6205-2RS	Scotch, 95-A, Polyurethane
HY 4609399	Load Wheel	Load Wheel Assembly, with Stainless Steel Bearing & String Guards, 95-A	3.250/83	4.500/114	2.047/52	BS 6205-2RS-SS	Scotch, 95-A, Polyurethane
HY 2081800-XL	Load Wheel	Load Wheel Assembly, with Shielded Bearings & String Guards, 97-A	3.250/83	4.500/114	2.047/52	BS 6205-ZZ	Cream, 97-A, Polyurethane
HY 2081796-XL	Load Wheel	Load Wheel Assembly, with Sealed Bearings & String Guards, 97-A	3.250/83	4.500/114	2.047/52	BS 6205-2RS	Cream, 97-A, Polyurethane
HY 4609399-XL	Load Wheel	Load Wheel Assembly, with Stainless Steel Bearing & String Guards, 97-A	3.250/83	4.500/114	2.047/52	BS 6205-2RS-SS	Cream, 97-A, Polyurethane
HY 800127595	Load Wheel	Load Wheel Assembly, with String Guards and Axle					
<a href="#">GWK-W40Z-LW</a>	Load Wheel Kit	(2) Poly Load Wheel Assemblies, with (2) Axles and Fasteners	3.250/83	4.500/114	2.047/52	BS 6205-2RS	Scotch, 95-A
<a href="#">GWK-W40Z-LW-XL</a>	Load Wheel Kit	(2) XL-Poly Load Wheel Assemblies, with (2) Axles and Fasteners	3.250/83	4.500/114	2.047/52	BS 6205-2RS	Cream, 97-A
<a href="#">GWK-W45Z-LW</a>	Load Wheel Kit	(2) Poly Load Wheel Assemblies, with (2) Axles and Fasteners	3.250/83	4.500/114	2.047/52	BS 6205-2RS	Scotch, 95-A
<a href="#">GWK-W45Z-LW-XL</a>	Load Wheel Kit	(2) XL-Poly Load Wheel Assemblies, with (2) Axles and Fasteners	3.250/83	4.500/114	2.047/52	BS 6205-2RS	Cream, 97-A
HY 2108789	Riser & Load Wheel	Complete Riser & Load Wheel Assembly, 95-A					Scotch, 95-A, Polyurethane
HY 2108789-XL	Riser & Load Wheel	Complete Riser & Load Wheel Assembly, 97-A					Cream, 97-A, Polyurethane
HY 2309963	Rubber Drive Tire	Rubber Drive Tire, Smooth Flat	9.00/229	5.00/127			Black Rubber
HY 2309963-XG	Rubber Drive Tire	Rubber Drive Tire, X Groove	9.00/229	5.00/127			Black Rubber
HY 2082237	Rubber Drive Tire	Rubber Drive Tire Assembly, Smooth Flat With Hub	9.00/229	5.00/127			Black Rubber
HY 2082237-XG	Rubber Drive Tire	Rubber Drive Tire Assembly, X Groove With Hub	9.00/229	5.00/127			Black Rubber
HY 2094227	Poly Drive Tire	Poly Drive Tire, Smooth Flat	9.00/229	5.00/127			Black, 88-92-A, Polyurethane
HY 2094227-XG	Poly Drive Tire	Poly Drive Tire, X Groove	9.00/229	5.00/127			Black, 88-92-A, Polyurethane
HY 2086274	Poly Drive Tire	Poly Drive Tire Assembly, Smooth Flat With Hub	9.00/229	5.00/127			Black, 88-92-A, Polyurethane
HY 2086274-XG	Poly Drive Tire	Poly Drive Tire Assembly, X Groove With Hub	9.00/229	5.00/127			Black, 88-92-A, Polyurethane
HY 2082486	Wheel Hub	Drive Tire Hub					



[HY 800127595](#)  
[Load Wheel Assembly w/String Guards and Axle](#)



[HY 2108789](#)  
[Complete Riser and Load Wheel Assembly](#)



[GWK-W40Z-LW](#)  
[Load Wheel Assembly Kit w/Bearings, Axles and Fasteners](#)



[HY 2082237](#)  
[Rubber Drive Tire w/Hub](#)

## Electrical - Battery Tray and Charger

## Electrical - Battery Tray and Charger

[back to Contents](#)



Item	Part No.	Date/Serial Range	Description
1	HY 2048103		Battery Tray
2	HY 2048079	Thru 9/2002	Battery Charger, 24V,120vac, Micro Control
	HY 2054228	10/2002 thru 4/2005	Battery Charger, 24V,120vac, Micro Control
	HY 2073416	4/2005 thru 11/2007	Battery Charger, 24V,120vac, Micro Control
	HY 2102631	12/2007 thru B218N18159G	Battery Charger, 24V,120vac, Micro Control
	HY 4603626	B218N18160G & B218N26948L	Battery Charger, 24V,120vac, Micro Control
3	HY 4075488	B218N26949L & UP	Battery Charger, 24V,120vac (AGM Battery)
	HY 4075269	B218N26949L & UP	Battery Charger, 24V,120vac (Flooded Battery)
4	HY 2056730		Battery Cover
5	HY 2058202		Utility Cover (Battery Cover)
6	HY 2078580		Knob
7	HY 61853		Fuse, 10 Amp

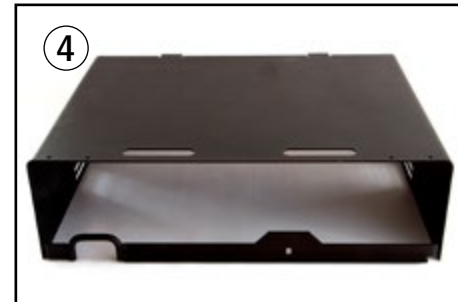



## Electrical - Control Panel

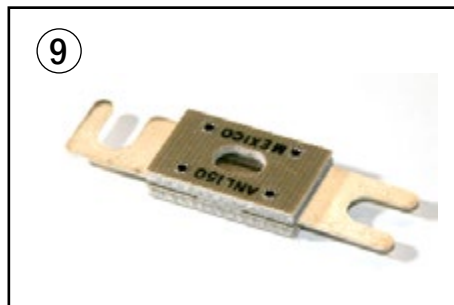

## Electrical - Control Panel

[back to Contents](#)

Item	Part No.	Date/Serial Range	Description
1	HY 2050771		Battery Cable & Red Connector (To Batteries)
2	HY 2045946		Battery Connector Red with Cable (To Panel)
3	HY 2059313		SBX 175 Amp Connector, Red
4	AN 6384G1		SBX Contacts, 175 Amp (Set of Two)
5	HY 4611682-R	W40Z / B218	Controller, 24 Volt, Remanufactured
	HY 4611682-C	W40Z / B218	Core Deposit
	HY 2046533-R	W45Z / C215	Controller, 24 Volt, Remanufactured
	HY 2046533-C	W45Z / C215	Core Deposit
6	HY 254007		AM Replacement, will not work w/ OEM keys.
	HY 254007-OEM		OEM Replacement, will work w/ OEM keys
7	HY 262798		Keys, Set of (2)
8	HY 2046546		Battery Discharge Indicator W/ Wire Harness
9	HY 2053654		Fuse, 175 Amp
10	HY 370646		Fuse, 5 Amp
11	HY 2042675		Horn, Safe-T-Alert, 2000 Series, 12-24V, 102 DB
12	HY 2047721		Main Wiring Harness, 24 Volt
13	HY 2038652		Ground Static Strap
14	HY 2054270	W40Z / B218	Contactor, 24 Volt (S/N B218)
	HY 2046797	W45Z / C215	Contactor, 24 Volt (S/N C215)

## Drive Unit and Brake Assembly

## Drive Unit and Brake Assembly

[back to Contents](#)

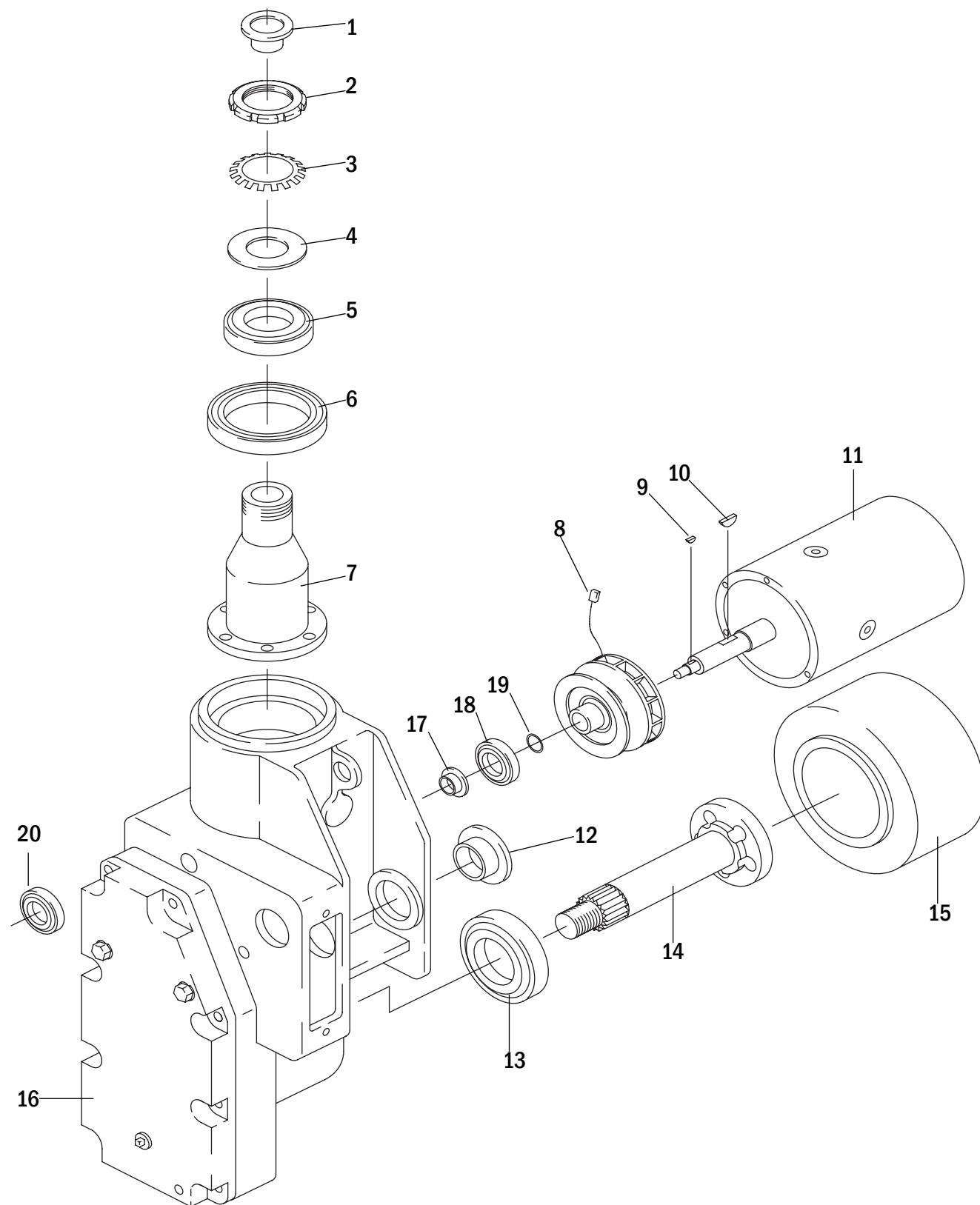

Item	Part No.	Description
1	HY 2307321	Sleeve
2	HY 2050733	Nut
3	HY 2050732	Lockwasher
4	HY 2048081	Seal
5	HY 1375474	Bearing Set
6	HY 1507273	Bearing Set
7	HY 2048043	Spindle
8	HY 2046003	Brake Assembly
9	HY 2310849	Woodruff Key
10	HY 2051303	Key
11		See Motor Section (Page 12)
12	HY 2791987	Bushing
13	HY 163971 HY 174230	Bearing Cup Bearing Cone
14	HY 2304321	Drive Axle
15		See Quick Wheel Lookup Section (Page 4)
16	HY 2051304	Drain Plug
17	HY 2059341	Spacer (Oil Flinger)
18	HY 128450	Bearing
19	HY 39382	O-Ring
20	HY 43203	Bearing

## Motors

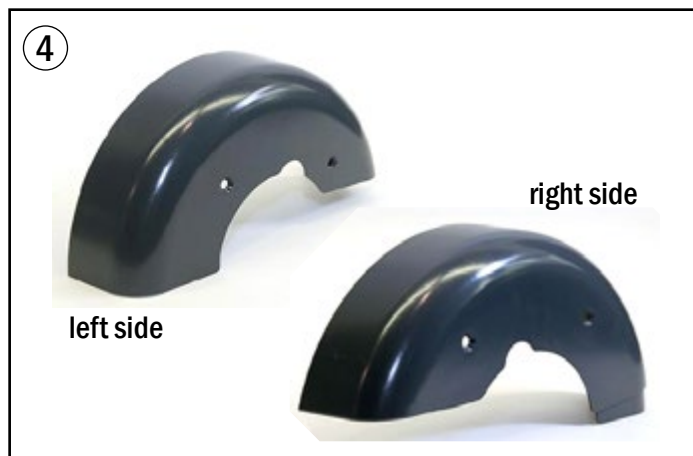
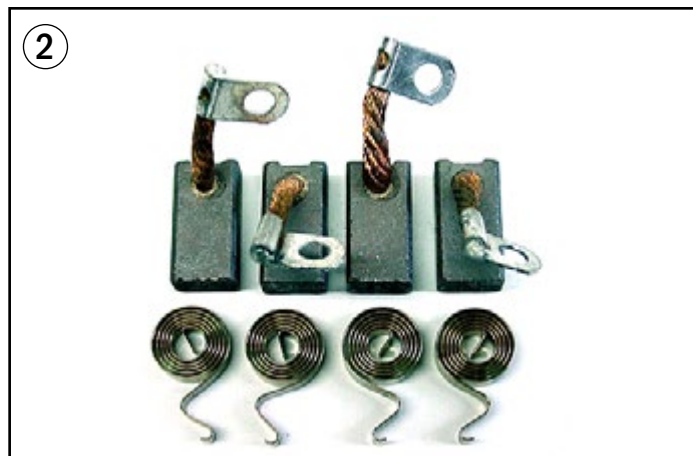

## Motors

[back to Contents](#)

Item	Part No.	Date/Serial Range	Description
1	HY 2049316		Traction Motor, 24 Volt, After-Market
2	HY 1506791-AM		Traction Motor Brush & Spring Set, After-Market Motor
3	HY 1506791		Traction Motor Brush & Spring Set, OEM Motor
4	HY 1537410		Motor Cover, Right Hand Side
	HY 1537409		Motor Cover, Left Hand Side
5	HY 1466025	B218	Pump Motor, 24 Volt, After-Market Replacement (B827)
	HY 1506120	C215	Pump Motor, 24 Volt, After-Market Replacement (B802)



## Tiller Arm



## Tiller Arm

[back to Contents](#)

Item	Part No.	Date/Serial Range	Description
1	HY 2050082	Up to S/N B218N18567G	Tiller Handle Arm
	HY 4009141	Begin S/N B218N18568G & Later	Tiller Handle Arm
2	HY 2050083	Thru S/N B218N03170A	Gas Spring, W40Z, Cold Storage
		Thru S/N B218N03330A	Gas Spring, W40Z, Standard
		Thru S/N C215N01669A	Gas Spring, W45Z
	HY 2059967	S/N B218N03171A - S/N B218N05460B	Gas Spring W/ Wiper, W40Z
		S/N B218N03331A - S/N B218N05460B	Gas Spring W/ Wiper, W40Z
		S/N C215N01670A - S/N C215N01888B	Gas Spring W/ Wiper, W45Z
HY 2066312	S/N B218N05461B - S/N B218N15399F	Gas Spring, W40Z	
	S/N C215N01889B & Later	Gas Spring, W45Z	
	S/N B218N15400F & Later	Gas Spring, W40Z	
3	HY 302375	Up to S/N B218N18567G	Pin
	HY 302380	Begin S/N B218N18568G & Later	Pin
4	HY 2077505		Proximity Sensor
5	HY 2066432		Wire Harness, Tiller Handle
6	HY 2792053		Pin, Tiller Pivot (2 Required)
7	HY 2791931		Washer (2 Required)
8	HY 2050084		Bumper (2 Required)
9	HY 302043	Up to S/N B218N18567G	Screw
	HY 302045	Begin S/N B218N18568G & Later	Screw
10	HY 292680		Washer
11	HY 177599	Up to S/N B218N18567G	Clamp
	HY 1486566	Begin S/N B218N18568G & Later	Clamp
12	HY 296166	Units Built Before 2005	Cap screw
	HY 1510114	Units Built 2006 & Later	Bolt
	HY 4035852	Units Built 2006 & Later	Nut
13	HY 320157		Lock Washer
14	HY 292681		Washer
15	HY 2792378		Screw
16	HY 2008715		Plug (Not Shown)



## Control Handle Head

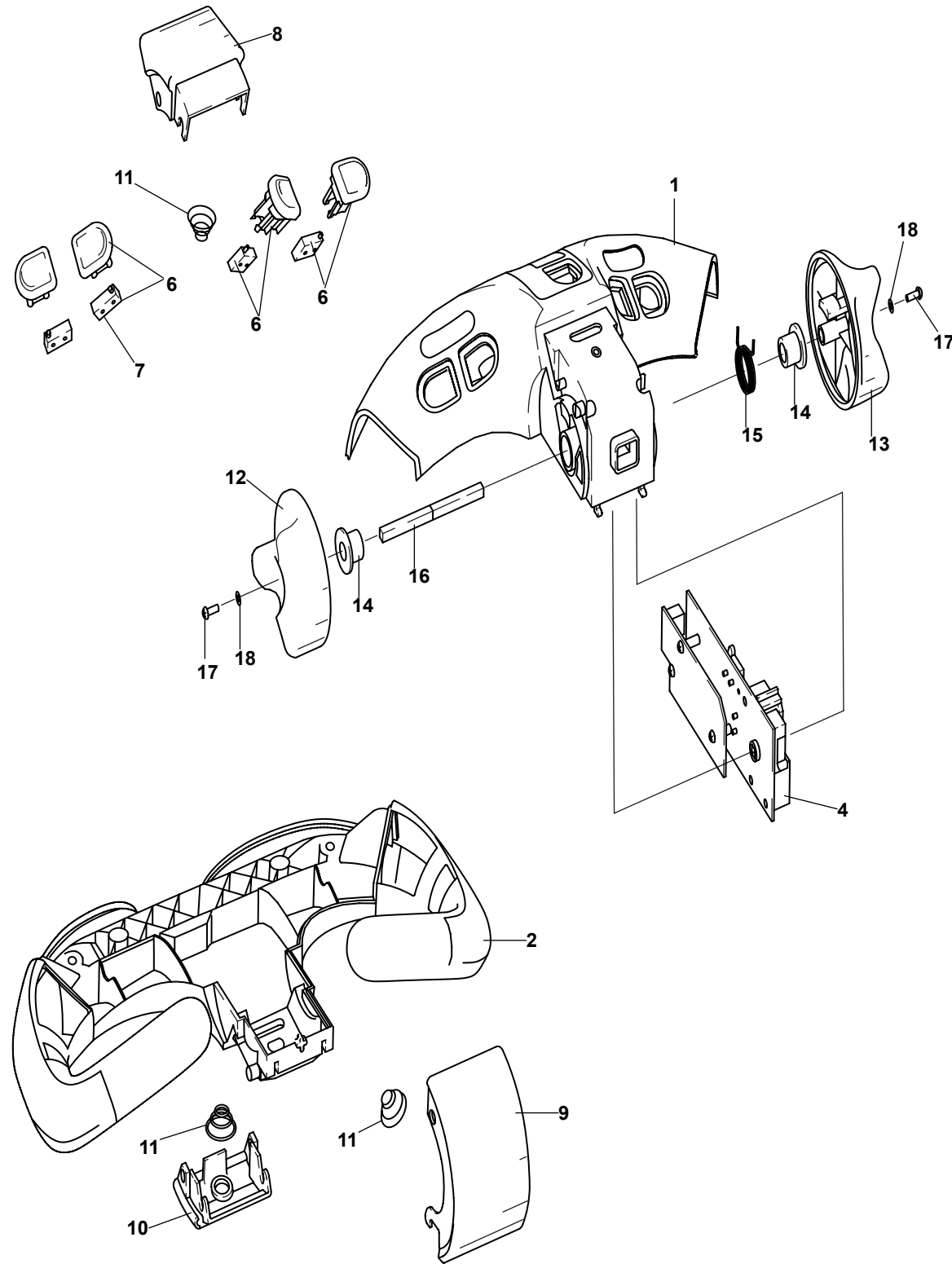

## Control Handle Head

[back to Contents](#)

Item	Part No.	Date/Serial Range	Description
	HY 1494881		Tiller Head Assembly
1	HY 2045501		Control Handle, Upper
2	HY 1467778	Thru 11/2003	Control Head, Lower
	HY 2060004	12/2003 thru 4/2009	Control Head, Lower
	HY 2111838	Begin 5/2009	Control Head, Lower
3	YL 550010160		Handle Upgrade Kit, Metal Grip (not shown)
4	HY 1498101-R	Thru 09/2005	Interface Board, Renewed
	HY 1498101-C		Core Deposit
	HY 1644784-R	09/2005 and Later	Interface Board, Renewed
	HY 1644784-C		Core Deposit
6	HY 1466877		Switch Assembly, Two Wire, RH & LH
7	HY 1498102		Microswitch, ON/Off Switch with Molex Connector
8	HY 1489471		Horn Cover
9	HY 1467779		Cover, Belly Switch
10	HY 1467780	Thru 09/2005	Cover, Turtle Option
	HY 1491262	09/2005 and Later	Cover, Turtle Option
11	HY 1531075		Spring (Belly/Horn/Turtle)
12	HY 1600593		Buttlerfly Switch, Left Hand
13	HY 1600592		Buttlerfly Switch, Right Hand
14	HY 1466595		Bushing, Butterfly Switch
15	HY 1594131		Spring, Throttle
16	HY 1466935		Camshaft, Directional Control
17	HY 1499660		Cap Screw
18	HY 320152		Washer

## Hydraulics

## Hydraulics

[back to Contents](#)

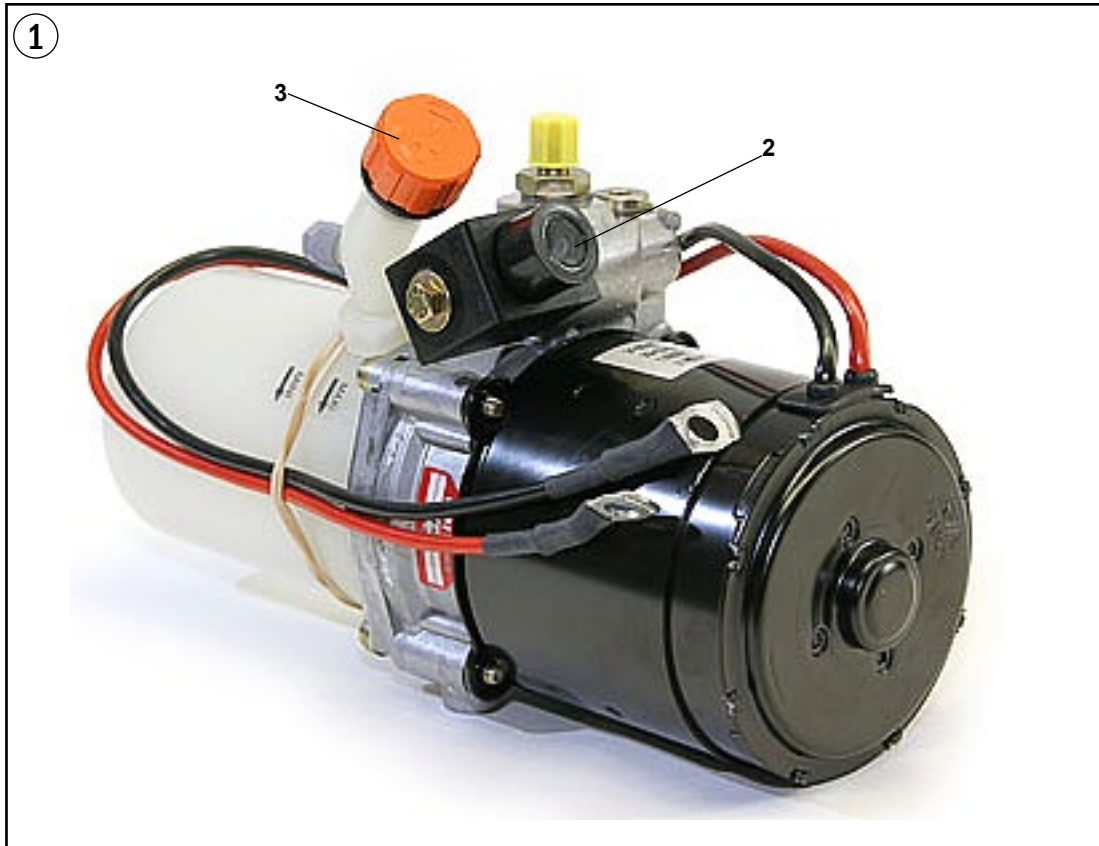

Item	Part No.	Date/Serial Range	Description
1	HY 2046104	Series B218, W40Z	Hydraulic Power Unit
	HY 2046133	Series C215, W45Z	Hydraulic Power Unit
			Hydraulic Motor See Motor Section (Page 12)
2	HY 1584237		Solenoid Valve
3	HY 388712		Breather
4	HY 2046539		Lift Cylinder
5	HY 2048665		Seal Kit, Lift Cylinder
6	HY 2302339		Hose
7	HY 16987		Fitting, Hose to Pump Body
8	HY 2048094		Fitting, Hose to Cylinder
9	HY 2070336		Tube (Not Shown)
10	HY 2309185		Fitting, Tube to Cylinder





## Load Wheel & Lift Linkage

## Load Wheel & Lift Linkage

[back to Contents](#)

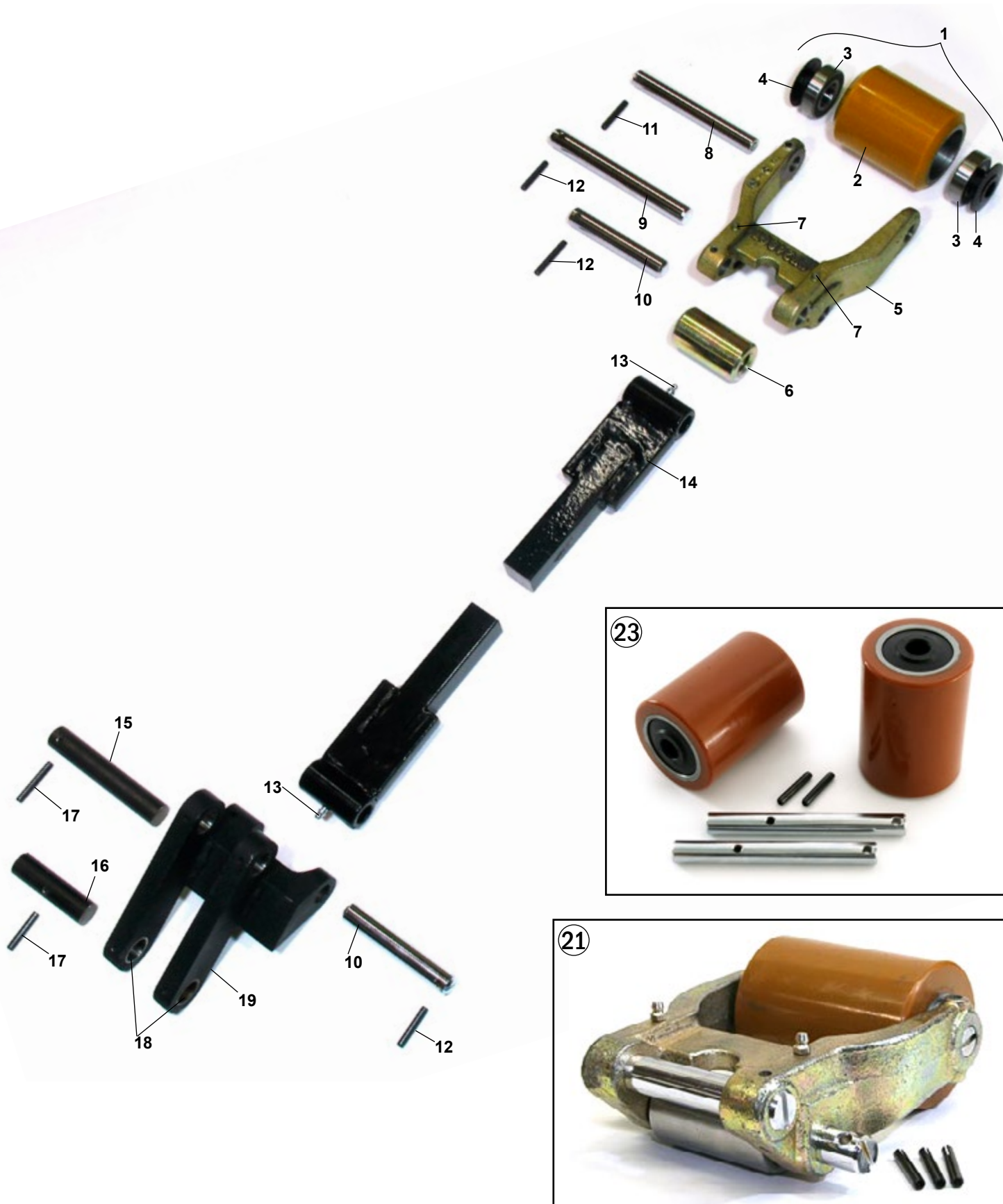

Item	Part No.	Description
1	HY 2081800	Load Wheel Assembly, with Shielded Bearings & String Guards, 95-A
	HY 2081796	Load Wheel Assembly, with Sealed Bearings & String Guards, 95-A
	HY 4609399	Load Wheel Assembly, with Sainless Steel Bearing & String Guards,95-A
	HY 2081800-XL	Load Wheel Assembly, with Shielded Bearings & String Guards, 97-A
	HY 2081796-XL	Load Wheel Assembly, with Sealed Bearings & String Guards, 97-A
2	HY 4609399-XL	Load Wheel Assembly, with Stainless Steel Bearing & String Guards,97-A
	HY 2046054	Poly Load Wheel, Poly 95-A
3	HY 2045989	Poly Load Wheel, Poly 97-A
	HY 2046055	Wheel Bearing, Rubber Seals
4	HY 2046056	Wheel Bearing, Metal Shields
	HY 2081792	Wheel Bearing, Stainless Steel
	HY 2046053	Bushing, String guard
5	HY 2046053	Riser Bracket
	HY 2081792	Riser Bracket
6	HY 2307475	Steel Exit Roller
7	HY 2045923	Lube Fitting
8	HY 2081802	Load Wheel Axle, Freezer/Corrosion Resistant
9	HY 2072210	Pivot Pin, Freezer/Corrosion Resistant
10	HY 2072211	Pivot Pin, Freezer/Corrosion Resistant
11	HY 2046059	Spiral Pin
12	HY 2050087	Spiral Pin
13	HY 2040833	Lube Fitting
14	HY 2085540	Push Rod, 48" Fork Length
15	HY 2072208	Pivot Pin, Freezer/Corrosion Resistant
16	HY 2072207	Pivot Pin, Freezer/Corrosion Resistant
17	HY 2050088	Spiral Pin
18	HY 2039225	Bushing
19	HY 2050085	Lower Rear Link, Right Hand Side
20	HY 2050086	Lower Rear Link, Left Hand Side (not shown)
21	HY 2043251	Complete Riser Assembly with Load Wheel Assembly, 95-A
	HY 2043251-XL	Complete Riser Assembly with Load Wheel Assembly, 97-A
22	HY 800127595	Poly Load Wheel & Axle Assembly, 95-A
	HY 800127595-XL	Poly Load Wheel & Axle Assembly, 97-A
23	GWK-W40Z-LW	Load Wheel Kit: (2) Poly Load Wheel Assemblies, with (2) Axles and Fasteners
	GWK-W40Z-LW0XL	Load Wheel Kit: (2) XL-Poly Load Wheel Assemblies, with (2) Axles and Fasteners
	GWK-W45Z-LW	Load Wheel Kit: (2) Poly Load Wheel Assemblies, with (2) Axles and Fasteners
	GWK-W45Z-LW-XL	Load Wheel Kit: (2) XL-Poly Load Wheel Assemblies, with (2) Axles and Fasteners



## Caster Assembly - Skid Bar

## Caster Assembly - Skid Bar

[back to Contents](#)

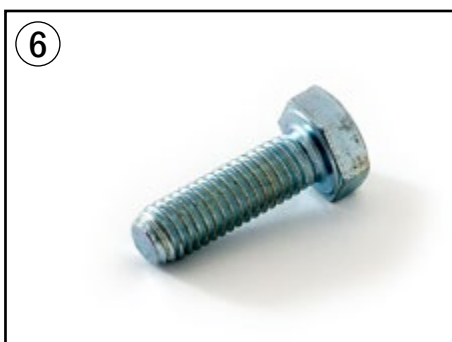
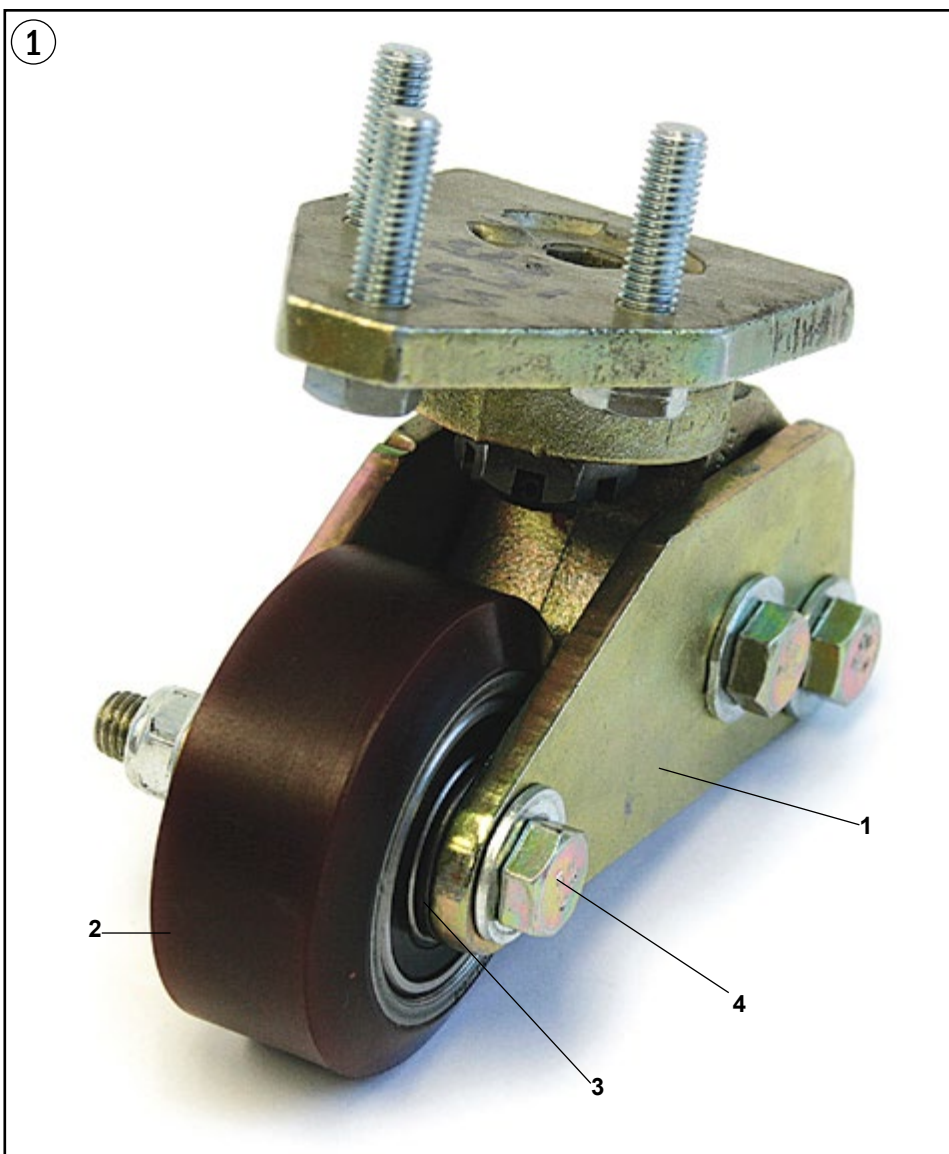

Item	Part No.	Date/Serial Range	Description
1	HY 2044852		Caster Assembly, After-Market Replacement
2	HY 2046840		Caster Wheel Assembly, 95-A, Incl Bearings
	HY 2046840-XL		Caster Wheel Assembly, 97-A, Incl Bearings
3	HY 2046842		Bushing
4	HY 2046768		Axle, Bolt & Nut
5	HY 2083830		Stabilizer
6	HY 287860		Capscrew
7	HY 292682		Lockwasher



**800-462-2370**

[www.SuperStoresService.com](http://www.SuperStoresService.com)

**800-462-2370**

[www.SuperStoresService.com](http://www.SuperStoresService.com)

