

Valu-Jack 5500-2 Frame

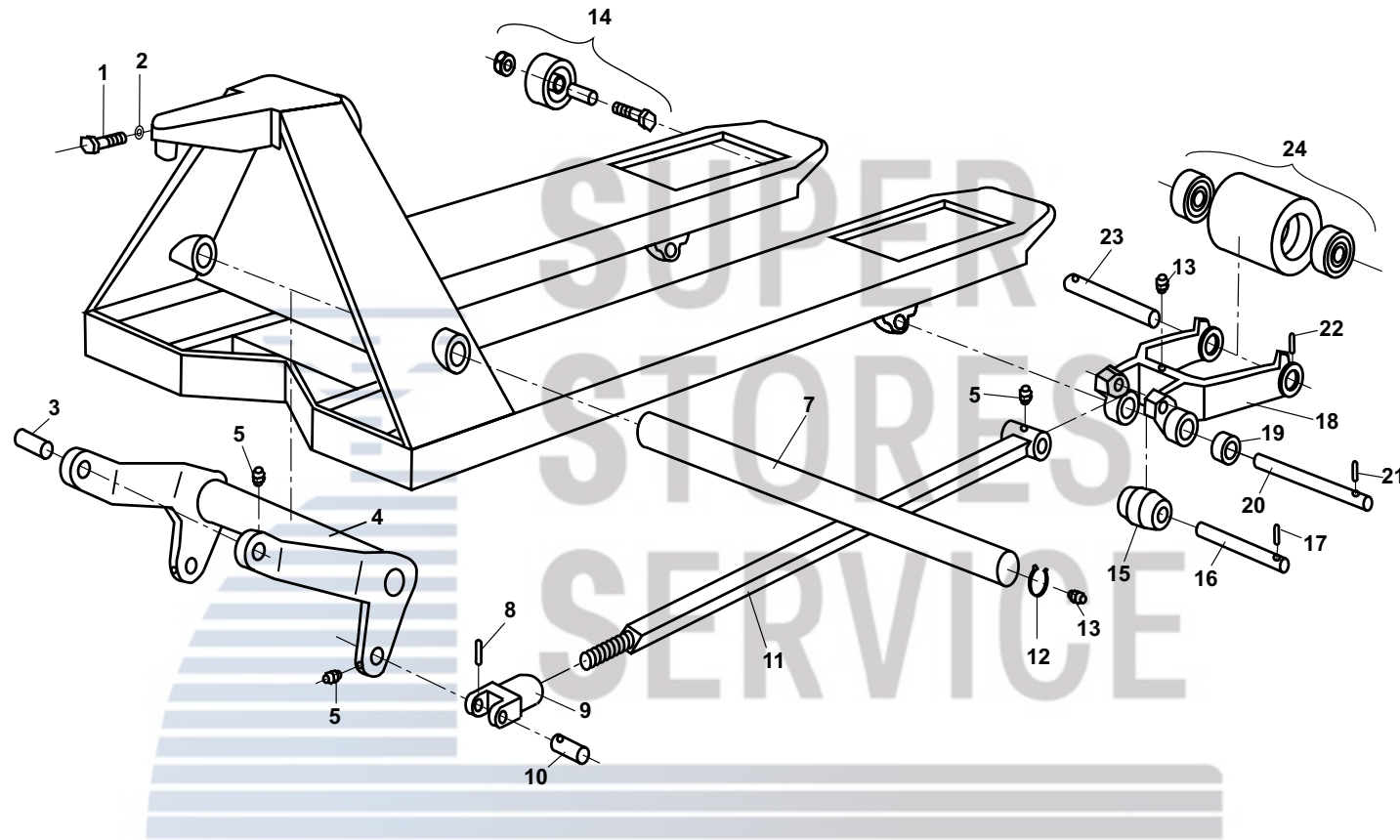

Valu-Jack 5500-2 Frame

Item	Part No.	Description
1	55F42	Bolt
2	55F41	Washer
3	55F14	Pin
4	55F43	Lifting Link, 27" wide frame
	55F43-20.5	Lifting Link, 20.5" wide frame
5	55F22	Lube Fitting
7	55F20	Shaft, 27" wide fork
	55F20-20.5	Shaft, 27" wide fork
8	55F16	Roll Pin
9	55F17	Rod Fitting, Clevis
10	55F18	Pin
11	55F19	Push Rod, 48" Forks
	55F19-36	Push Rod, 36" Forks
12	55F21	Retaining Ring
13	55F15	Lube Fitting
14	55F36A	Entry Roller Assy, Inc. Axle, Nut, Roller & Sleeve
	55F36	Entry Roller

Item	Part No.	Description
15	55F23	Exit Roller
16	55F25	Shaft
17	55F24	Roll Pin
18	55F31	Load Roller Bracket
19	55F28	Intermediate Exit Roller
20	55F26	Shaft
21	55F27	Roll Pin
22	55F30	Roll Pin
23	55F29	Shaft
24	55F35	Load Wheel Assembly, Ultra Poly 70D Black W/Bearings
	55F35N	Load Wheel Assembly, White Nylon W/Bearings
	55F35S	Load Wheel Assembly, Steel W/Bearings
	GWK-VJ2-LW	Load Wheel Kit, (2) Ultra Poly Load Wheels 70D, W/Bearings, Axles & Fasteners

Load Wheel Kit

